

MUELLER® NO-BLO® GAS METER VALVE CHANGER

Normally, the gas meter valve provides the primary shut-off point on the gas service line. If this valve needs to be replaced for any reason, there is often no other convenient shut-off point upstream of the valve. The Mueller NO-BLO Valve Changer provides a safe, effective and easy to use means for stopping gas flow upstream of the meter valve allowing the valve to be replaced. It also allows the MIP threads on the riser to be refurbished, if necessary.

The Mueller valve changer – a Mueller NO-BLO System exclusive – which includes plugging units and safety clamps, can be used on most straightway and round way meter valves in sizes ranging from 1/2" through 2" if the valve has an FIP outlet and the port through the valve will permit the passage of the valve changer's plugging unit.

Mueller® NO-BLO® Gas Meter Valve Changer

- ❑ PLUGGING UNIT – available in sizes and styles to match all Mueller brands and most other brands of meter valves. Each unit is designed for a specific size and style of valve. The rubber plug on the end of the unit can provide repeated stop-offs if properly maintained.
- ❑ SAFETY CLAMP – should be clamped securely to the end of the riser and allows complete control of the plugging unit at all times during the valve removal or thread refurbishing operations. Provided to guard against the accidental ejection of the plugging unit under gas pressure.



- ❑ WOODEN STORAGE CHEST (not shown) – sturdy, convenient storage for the safety clamp and several different sizes of plugging units.
- ❑ OPERATING INSTRUCTIONS – Easy to follow, step by step instructions for using the Mueller NO-BLO Valve Changer to change meter valves and refurbish the threads on the riser outlet end without gas escaping.

Rev 12-12 Shaded area indicates a change

- ❑ Catalog number – **H-17010**
- ❑ For changing out 3/4" to 1-1/4" Meter Valves installed on schedule 40 steel pipe
- ❑ Includes three Plugging Units, Safety Clamp, Wooden Storage Chest (**680350**) and Operating Instructions (Form **8540**)
- ❑ Fits most roundway and straightway valves
- ❑ O-ring sealed body and stem
- ❑ Maximum working pressure 60 psig** (414 kPa)

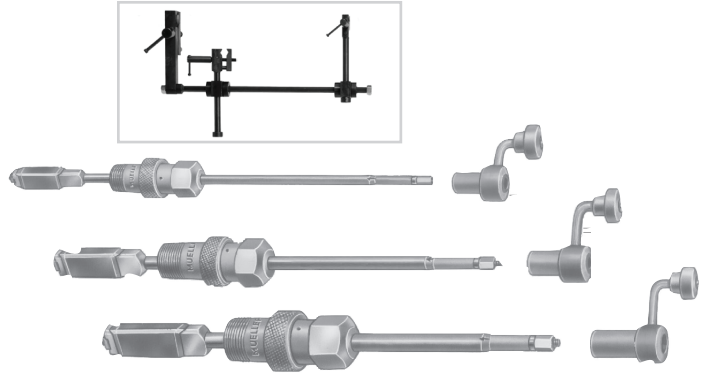

H-17010

Dimensions

The H-17010 plugging units can be used on valves (roundway or straightway) that have minimum port dimensions charted to the right, and if the outlet of the valve has F.I.P. threads.

Valve Size*	Minimum Port Width	Minimum Port Height
3/4"	13/32"	23/32"
1"	17/32"	31/32"
1-1/4"	11/16"	1-9/32"

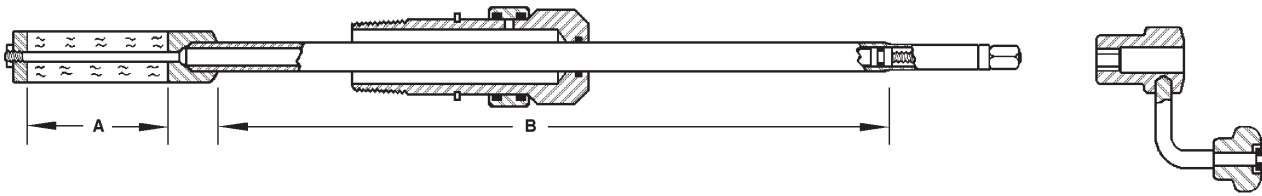

Size* of Plugging Unit	3/4"	1"	1-1/4"
Plugging unit part number	83962	83963	83964
A length of rubber plug	2"	2-5/8"	3-3/8"
B length from ferrule shoulder to taper	12-9/16"	12-9/16"	12-9/16"

Safety Clamp

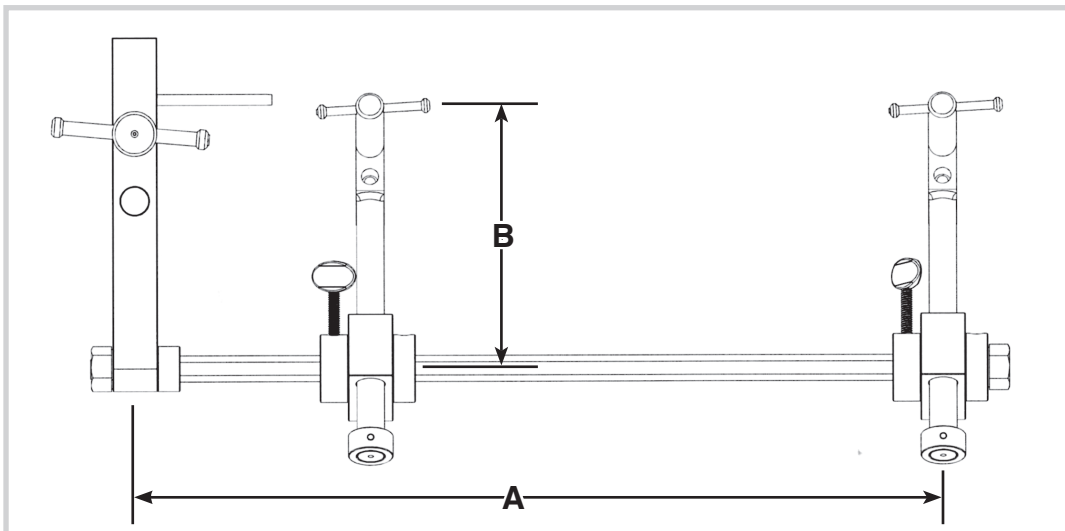

Safety Clamp Part Number	A	B
682597	20"	6-1/2"

*Nominal
 ** This is the maximum working pressure of this equipment. During the use of this equipment, the line pressure must not exceed the amount indicated.

H-17010 VALVE CHANGER REPLACEMENT PARTS

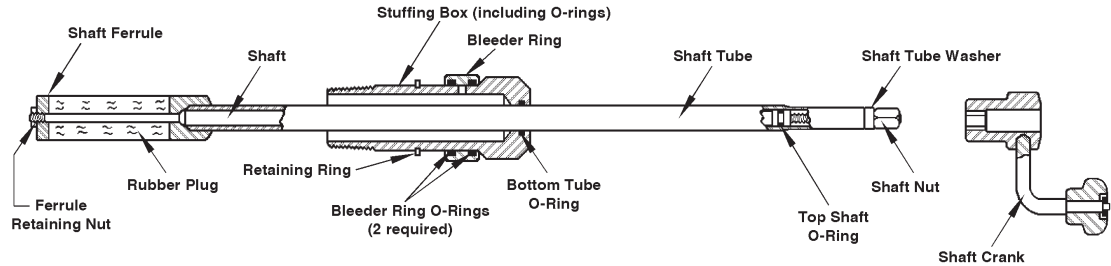

Part Name	Plugging Unit Size*		
	3/4"	1"	1-1/4"
Plugging Unit Complete	83962	83963	83964
Stuffing Box Assembly	83281	83282	83283
Bottom Tube O-ring	79514	72239	79344
Retaining Ring	53777	50990	51014
Bleeder Ring	50936	50947	51003
Bleeder O-ring (2)	40709	79351	79479
Shaft Crank Assembly	83276	83277	83278
Shaft Nut	51134	51249	51101
Shaft Tube Washer	51159	51059	51110
Top Shaft O-ring	53856	43973	79514
Shaft Tube Assembly	83966	83968	580392
Shaft Assembly	83965	83967	580391
Rubber Plug	51243	51100	51113
Shaft Ferrule	51189	51288	51106
Shaft Ferrule Retaining Nut	52969	53832	53863

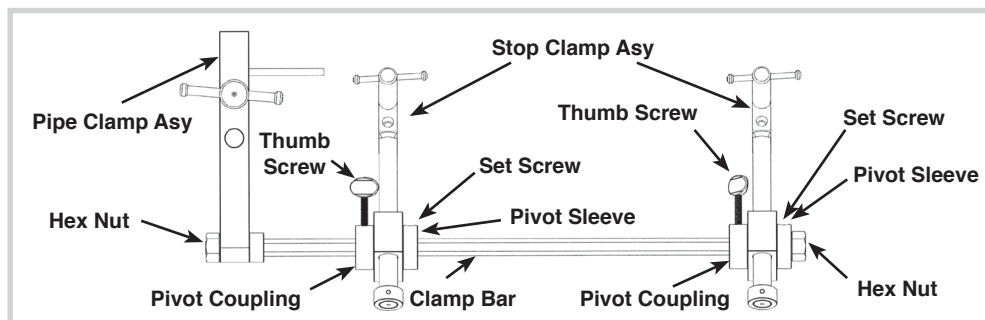

Part Name	Qty Req'd	Part Number
Safety Clamp Complete		682597
Pivot Sleeve	2	537866
Set Screw	2	97763
Pivot Coupling	2	537865 (Pivot Coupling)
Shaft Tube Clamp Arm Assembly (2)	2	682854
Clamp Bar	1	682598
Pipe Clamp Assembly	1	83977
Thumb Screw	2	95297
Hex Nut	2	94825

*Nominal

13.4



OPTIONAL EXTENDED LENGTH PLUGGING UNITS FOR 3/4", 1" & 1-1/4" METER VALVES ON SCH. 40 STEEL

Rev 12-12 Shaded area indicates a change

- Used for changing out 3/4", 1 or 1-1/4" Meter Valves installed on schedule 40 steel pipe when additional travel is required.
- Extended length Safety Clamp also available and preferred when using these longer Plugging Units.
- Fits most roundway and straightway valves
- O-ring sealed body and stem
- Maximum working pressure 60 psig** (414 kPa)

Dimensions

These plugging units can be used on valves (roundway or straightway) that have minimum port dimensions charted to the right, and if the outlet of the valve has F.I.P. threads.

Valve Size*	Minimum Port Width	Minimum Port Height
3/4"	13/32"	23/32"
1"	17/32"	31/32"
1-1/4"	11/16"	1-9/32"

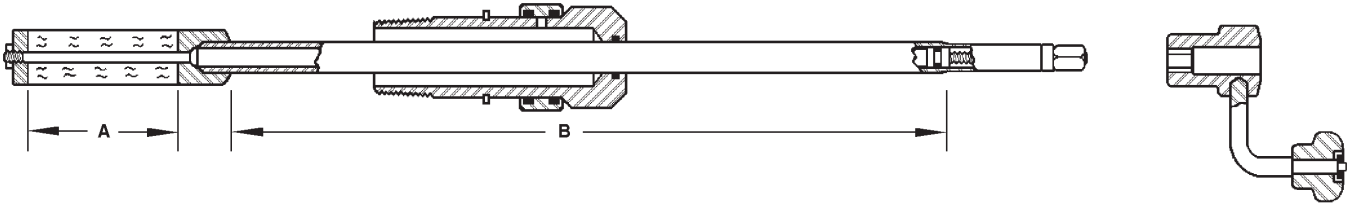

Size* of Plugging Unit	3/4"	3/4"	1"	1"	1"	1-1/4"	1-1/4"
Plugging Unit Part Number	580617	681427	580618	83866	580788	580621	681430
(A) Length of Rubber Plug	2"	2"	2-5/8"	2-5/8"	2-5/8"	3-3/8"	3-3/8"
(B) Length from ferrule shoulder to taper	18-13/32"	31-9/16"	18-13/32"	27-5/8"	30-27/32"	18-13/32"	29-29/32"

Safety Clamp (extended length)

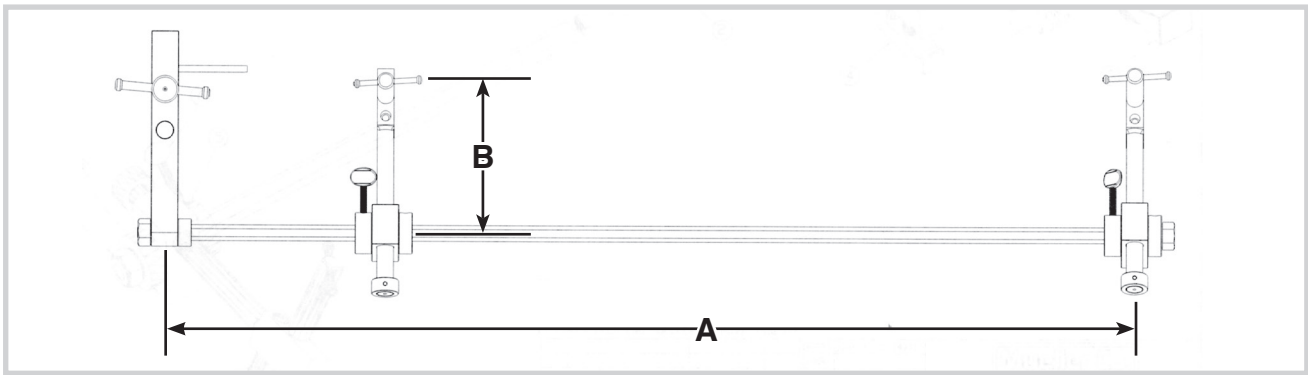

Safety Clamp Part Number	A	B
682857	38"	6-1/2"

*Nominal
 * This is the maximum working pressure of this equipment. During the use of this equipment, the line pressure must not exceed the amount indicated.

EXTENDED LENGTH PLUGGING UNIT REPLACEMENT PARTS



13.5

Shaded area indicates a change REV. 6-10

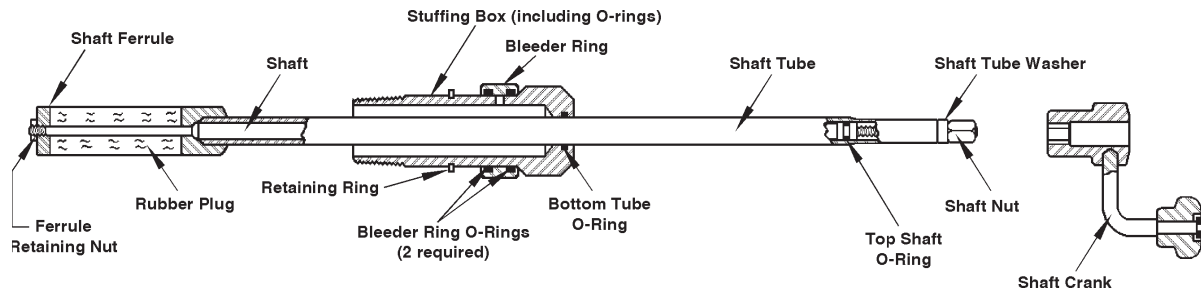

Part Name	Plugging Unit Size* (extended length)							
	3/4"	3/4"	3/4"	1"	1"	1"	1-1/4"	1-1/4"
Plugging Unit Complete	580617 24"	83865 29"	681427 36"	580618 24"	83866 33"	580788 36"	580621 24"	681430 36"
Stuffing Box Assembly	681183	681181	681181	83282	83282	83282	83283	83283
Bottom Tube O-ring	79514	79514	79514	72239	72239	72239	79344	79344
Retaining Ring	53777	53777	53777	50990	50990	50990	51014	51014
Bleeder Ring	50936	50936	50936	50947	50947	50947	51003	51003
Bleeder O-ring (2)	40709	40709	40709	79351	79351	79351	79479	79479
Shaft Crank Assembly	83276	83276	83276	83277	83277	83277	83278	83278
Shaft Nut	51134	51134	51134	51249	51249	502609	51101	51101
Shaft Tube Washer	51159	51159	51159	51059	51059	502607	51110	51110
Top Shaft O-ring	53856	53856	53856	43973	43973	43973	79514	79514
Shaft Tube Assembly	580615	83867	681428	580620	83868	580789	580622	580792
Shaft Assembly	580616	83869	681429	580619	83870	580790	580623	580793
Rubber Plug	51243	51243	51243	51100	51100	51100	51113	51113
Shaft Ferrule	51189	51189	51189	51288	51288	51288	51106	51106
Shaft Ferrule Retaining Nut	52969	52969	52969	53832	53832	53832	53863	53863

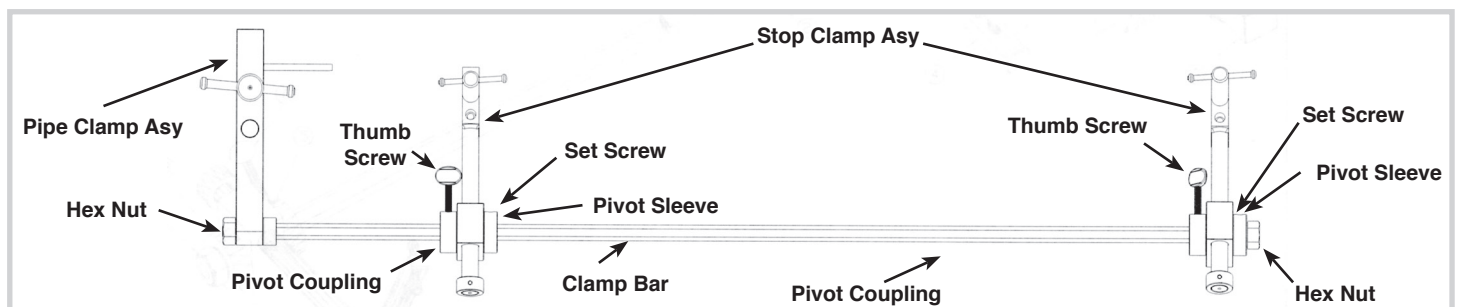

Part Name	Qty Req'd	Part Number
Safety Clamp Complete		682857
Pivot Sleeve	2	537866
Set Screw	2	97763
Pivot Coupling	2	537865 (Pivot Coupling)
Shaft Tube Clamp Arm Assembly (2)	2	682854
Clamp Bar	1	682795
Pipe Clamp Assembly	1	83977
Thumb Screw	2	95297
Hex Nut	2	94825

*Nominal

13.6



H-17012 MUELLER® NO-BLO VALVE CHANGER FOR 1-1/2" & 2" METER VALVES ON SCH. 40 STEEL

REV. 6-10 Shaded area indicates a change

- ❑ Catalog number – **H-17012**
- ❑ For changing out 1-1/2" and 2" Meter Valves installed on schedule 40 steel pipe
- ❑ Includes two plugging units, safety clamp, wooden storage chest (680288) and operating instructions (Form 8540)
- ❑ Fits most roundway and straightway valves
- ❑ O-ring sealed body and stem
- ❑ Maximum working pressure 60 psig** (414 kPa)

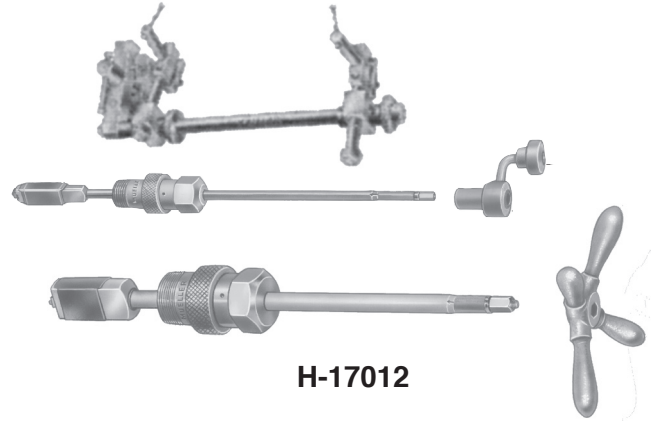

H-17012

Dimensions

The H-17012 plugging units can be used on valves (roundway or straightway) that have minimum port dimensions charted to the right, and if the outlet of the valve has F. I. P. threads.

Valve Size*	Minimum Port Width	Minimum Port Height
1-1/2"	25/32"	1-19/32"
2"	1-5/32"	2"

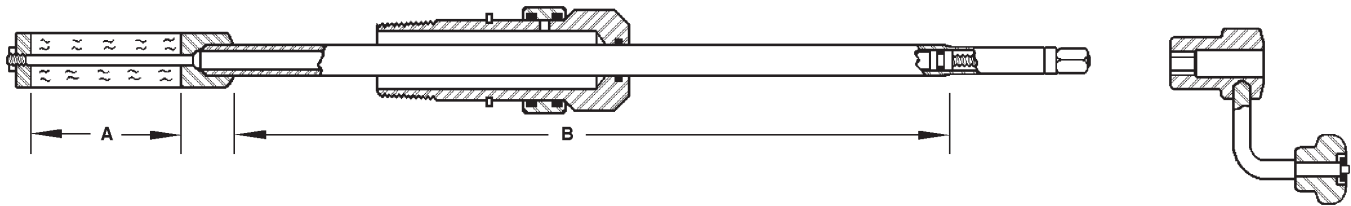

Size* of Plugging Unit	1-1/2"	2"
Plugging Unit Part Number	83805	83928
A Length of Rubber Plug	4-1/8"	3-1/8"
B Length from Ferrule Shoulder to taper	17-7/16"	17-7/16"

Safety Clamp

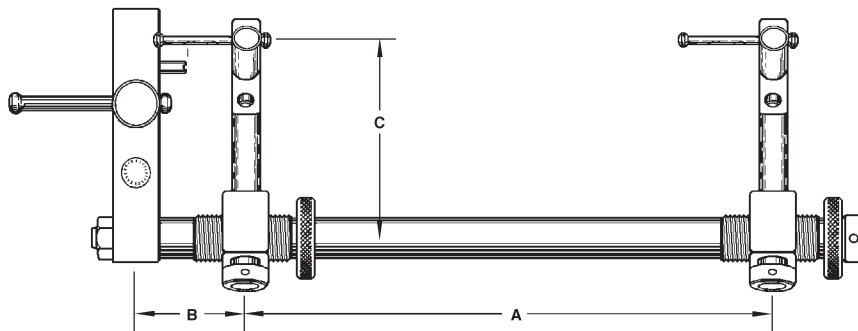

Safety Clamp Part Number	A	B	C
83792	17-7/16"	2-15/16"	6-5/16"

*Nominal
 ** This is the maximum working pressure of this equipment. During the use of this equipment, the line pressure must not exceed the amount indicated.

H-17012 VALVE CHANGER REPLACEMENT PARTS

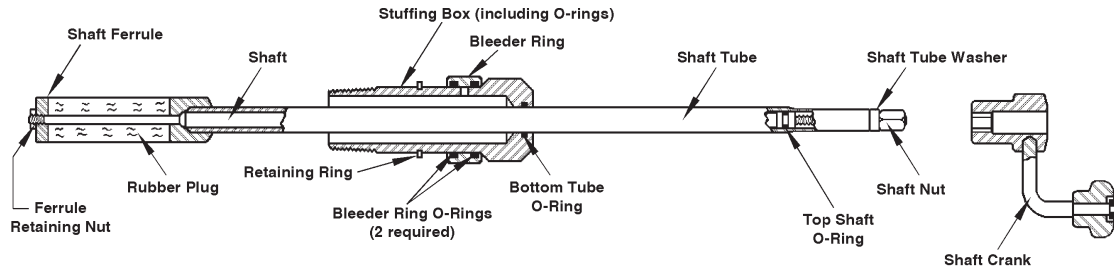

Part Name	Plugging Unit Size*		
	1-1/2"	2"	2"
Plugging Unit Complete	83805	83928	681431 (36")
Stuffing Box Assembly	83807	83943	83943
Bottom Tube O-ring	79344	503726	503726
Retaining Ring	500567	501204	501204
Bleeder Ring	500568	501177	501177
Bleeder O-ring (2)	78828	501205	501205
Shaft Crank Assembly	83806	501181	501181
Shaft Nut	51101	501180	501180
Shaft Tube Washer	51110	501182	501182
Top Shaft O-ring	79514	78818	78818
Shaft Tube Assembly	83803	83942	681432
Shaft Assembly	83808	83941	681433
Rubber Plug	500561	501183	501183
Shaft Ferrule	500560	501179	501179
Shaft Ferrule Retaining Nut	53863	53935	53935

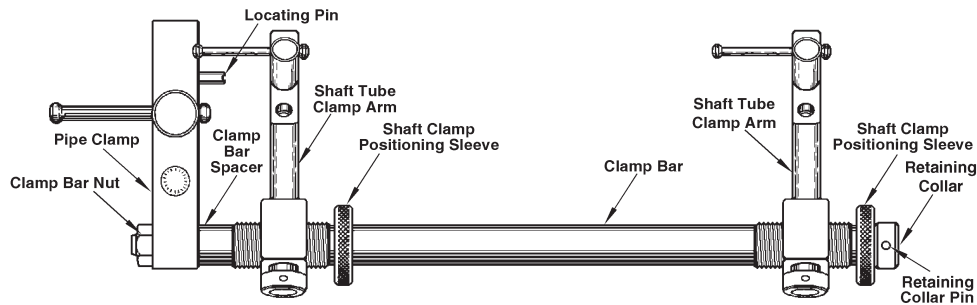

Part Name	Part Number	
Safety Clamp Complete	83792	682732 - extended length
Retaining Collar	500582	500582
Retaining Collar Pin	500580	500580
Shaft Clamp Positioning Sleeve (2)	500576	500576
Shaft Tube Clamp Arm Assembly (2)	83793	83793
Clamp Bar	500585	537486
Pipe Clamp Assembly	83798	83798
Clamp Bar Spacer	500575	500575
Clamp Bar Nut	33571	33571

*Nominal

Rev 12-12 Shaded area indicates a change

- ❑ Catalog number – **H-17013**
- ❑ For changing out 3/4", 1" and 1-1/4" Meter Valves installed on schedule 80 steel pipe
- ❑ Includes Three Plugging Units, Safety Clamp, Wooden Storage Chest (**680350**) and Operating Instructions (Form **8540**)
- ❑ Fits most roundway and straightway valves
- ❑ O-ring sealed body and stem
- ❑ Maximum working pressure 60 psig** (414 kPa)

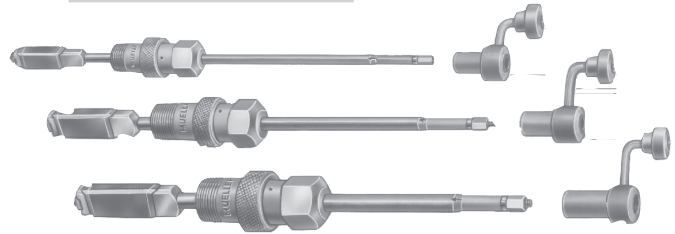
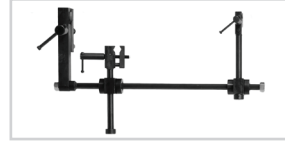

H-17013

Dimensions

The H-17013 Plugging Units can be used on valves (roundway or straightway) that have minimum port dimensions charted to the right, and if the outlet of the valve has F.I.P. threads.

Valve Size*	Minimum Port Width	Minimum Port Height
3/4"	13/32"	23/32"
1"	17/32"	31/32"
1-1/4"	11/16"	1-9/32"

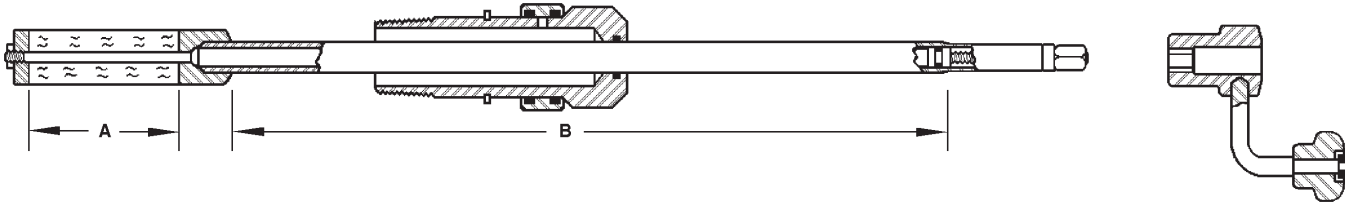

Size* of Plugging Unit	3/4"	1"	1-1/4"
Plugging Unit Part Number	83962	580530	580531
A Length of Rubber Plug	2"	2-5/8"	3-3/8"
B Length From Ferrule Shoulder to taper	12-9/16"	12-9/16"	12-9/16"

Safety Clamp

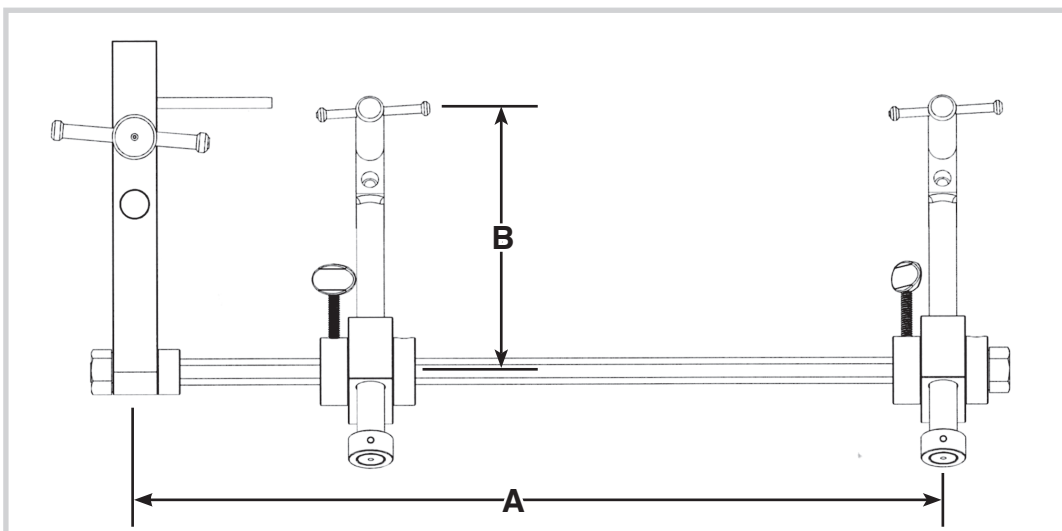

Safety Clamp Part Number	A	B
682597	20"	6-1/2"

*Nominal
 ** This is the maximum working pressure of this equipment. During the use of this equipment, the line pressure must not exceed the amount indicated.

H-17013 VALVE CHANGER REPLACEMENT PARTS

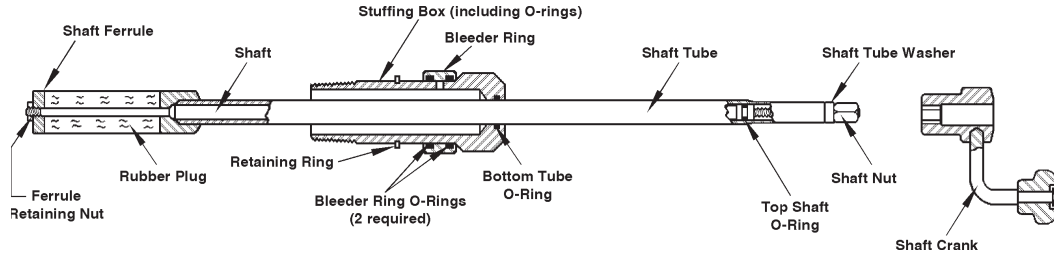

Part Name	Plugging Unit Size*		
	3/4"	1"	1-1/4"
Plugging Unit Complete	83962	580530	580531
Stuffing Box Assembly	83281	83282	83283
Bottom Tube O-ring	79514	72239	79344
Retaining Ring	53777	50990	51014
Bleeder Ring	50936	50947	51003
Bleeder O-ring (2)	40709	79351	79479
Shaft Crank Assembly	83276	83277	83278
Shaft Nut	51134	51249	51101
Shaft Tube Washer	51159	51059	51110
Top Shaft O-ring	53856	43973	79514
Shaft Tube Assembly	83966	83968	580392
Shaft Assembly	83965	83967	580391
Rubber Plug	51243	501139	501140
Shaft Ferrule	51189	501136	51106
Shaft Ferrule Retaining Nut	52969	53832	53863

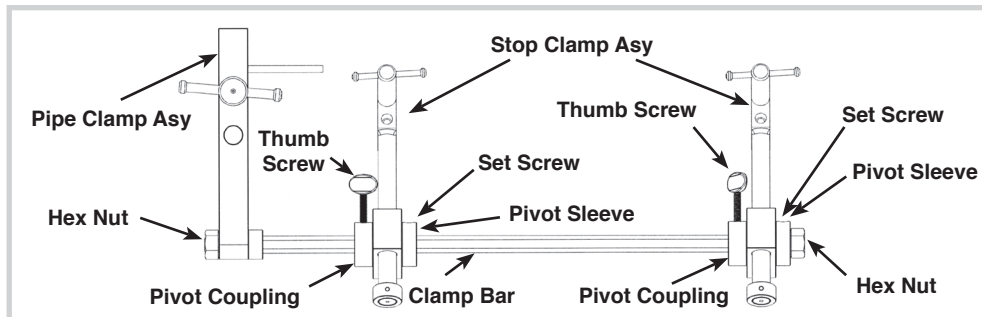

Part Name	Qty Req'd	Part Number
Safety Clamp Complete		682597
Pivot Sleeve	2	537866
Set Screw	2	97763
Pivot Coupling	2	537865 (Pivot Coupling)
Shaft Tube Clamp Arm Assembly (2)	2	682854
Clamp Bar	1	682598
Pipe Clamp Assembly	1	83977
Thumb Screw	2	95297
Hex Nut	2	94825

*Nominal

REV. 6-10 Shaded area indicates a change

- ❑ Catalog number – **H-17014**
- ❑ For changing out 1-1/2" and 2" meter valves installed on schedule 80 steel pipe
- ❑ Includes safety clamp, wooden storage chest (**680288**) and operating instructions (Form **8540**)
- ❑ Fits most roundway and straightway valves
- ❑ O-ring sealed body and stem
- ❑ Maximum working pressure 60 psig** (414 kPa)

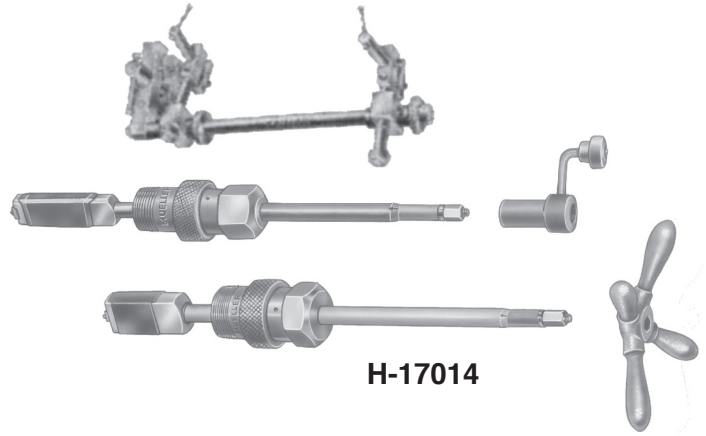

H-17014

Dimensions

The H-17014 plugging units can be used on valves (roundway or straightway) that have minimum port dimensions charted to the right, and if the outlet of the valve has F.I.P. threads.

Valve Size*	Minimum Port Width	Minimum Port Height
1-1/2"	25/32"	1-19/32"
2"	1-5/32"	2"

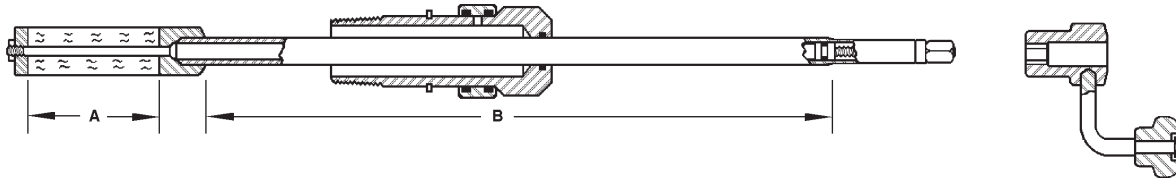

Size* of Plugging Unit	1-1/2"	2"
Plugging unit part number	580630	580750
A length of rubber plug	4-1/8"	3-1/8"
B length from ferrule shoulder to taper	17-7/16"	17-7/16"

Safety Clamp

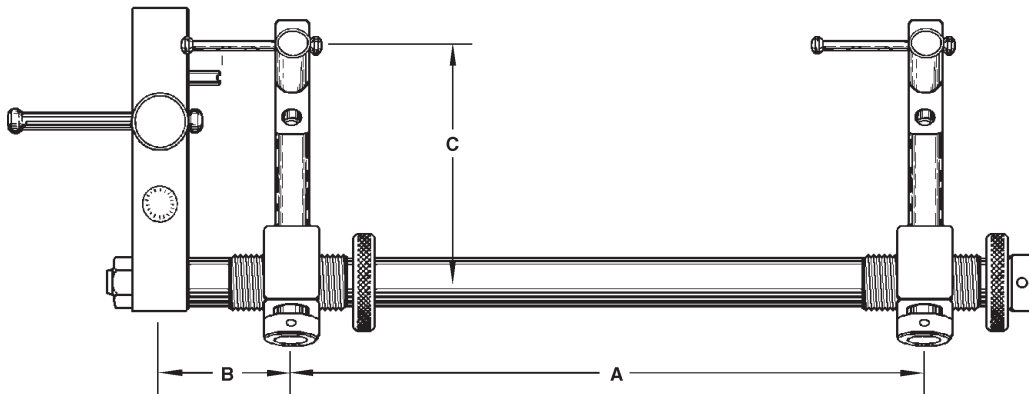

Safety Clamp Part Number	A	B	C
83792	17-7/16"	2-15/16"	6-5/16"

*Nominal
 ** This is the maximum working pressure of this equipment. During the use of this equipment, the line pressure must not exceed the amount indicated.

H-17014 VALVE CHANGER REPLACEMENT PARTS

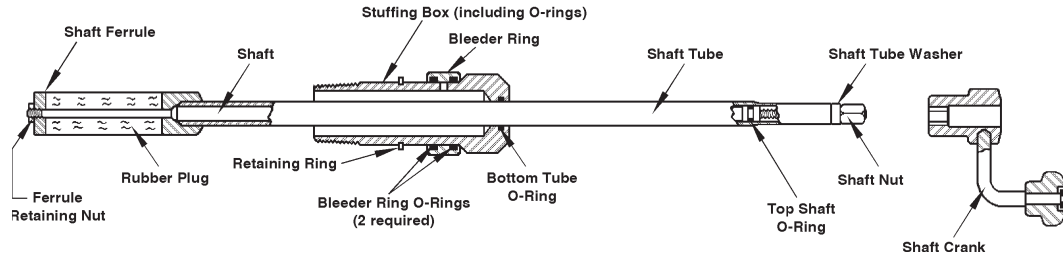

Part Name	Plugging Unit Size*	
	1-1/2"	2"
Plugging Unit Complete	580630	580750
Stuffing Box Assembly	83807	83943
Bottom Tube O-ring	79344	503726
Retaining Ring	500567	501204
Bleeder Ring	500568	501177
Bleeder O-ring (2)	78828	501205
Shaft Crank Assembly	83806	501181
Shaft Nut	51101	501180
Shaft Tube Washer	51110	501182
Top Shaft O-ring	79514	78818
Shaft Tube Assembly	580631	580749
Shaft Assembly	83808	83941
Rubber Plug	502044	502414
Shaft Ferrule	502045	502415
Shaft Ferrule Retaining Nut	53863	53935

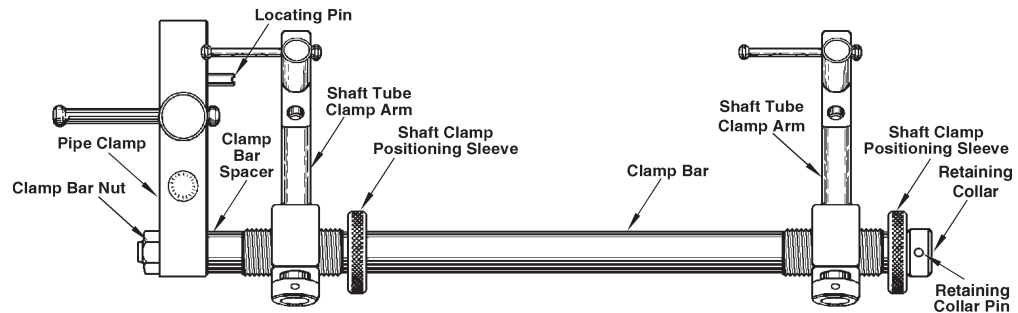

Part Name	Part Number
Safety Clamp Complete	83792
Retaining Collar	500582
Retaining Collar Pin	500580
Shaft Clamp Positioning Sleeve (2)	500576
Shaft Tube Clamp Arm Assembly (2)	83793
Clamp Bar	500585
Pipe Clamp Assembly	83798
Clamp Bar Spacer	500575
Clamp Bar Nut	33571

*Nominal

Rev 12-12 Shaded area indicates a change

- ❑ Catalog number – **H-17016**
- ❑ For changing out 3/4" or 1" meter valves installed on 1/2" CTS PE Risers
- ❑ Fits most roundway and straightway valves
- ❑ O-ring sealed body and stem
- ❑ Maximum working pressure 60 psig** (414 kPa)
- ❑ Used with Safety Clamp **682597** (order separately)***

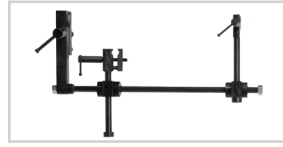

(Safety Clamp to be purchased separately)



Dimensions

This unit can be used on valves (roundway or straightway) that have minimum port dimensions charted to the right, and if the outlet of the valve has F.I.P. threads.

Valve Size*	Minimum Port Width	Minimum Port Height
3/4"	13/32"	23/32"
1"	13/32"	23/32"

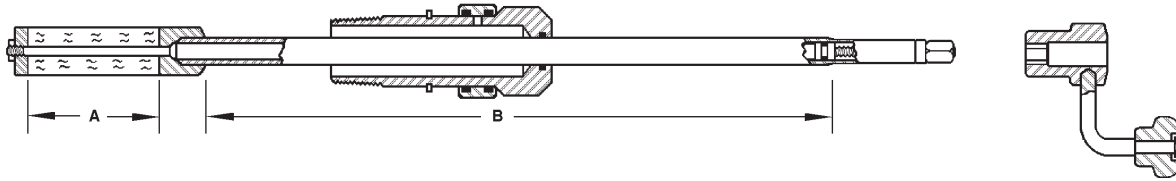

Size* of Plugging Unit	1/2" x 3/4"	1/2" x 1"
A Length of Rubber Plug	1-1/2"	1-1/2"
B Length From Ferrule Shoulder to taper	12-9/16"	12-9/16"

Safety Clamp***

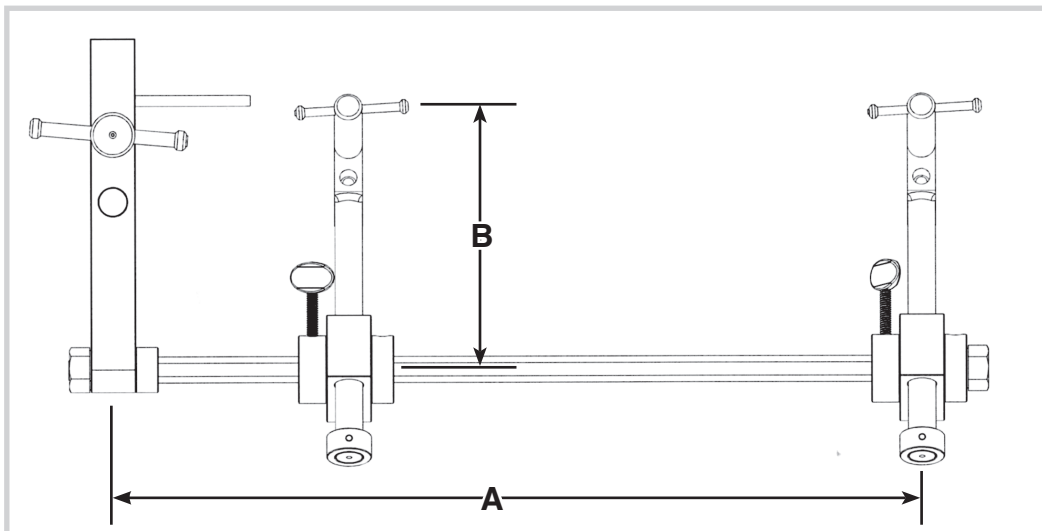

Safety Clamp Part Number	A	B
682597	20"	6-1/2"

*Nominal
 ** This is the maximum working pressure of this equipment. During the use of this equipment, the line pressure must not exceed the amount indicated.
 *** Safety clamp is required but must be purchased separately.

H-17016 VALVE CHANGER REPLACEMENT PARTS

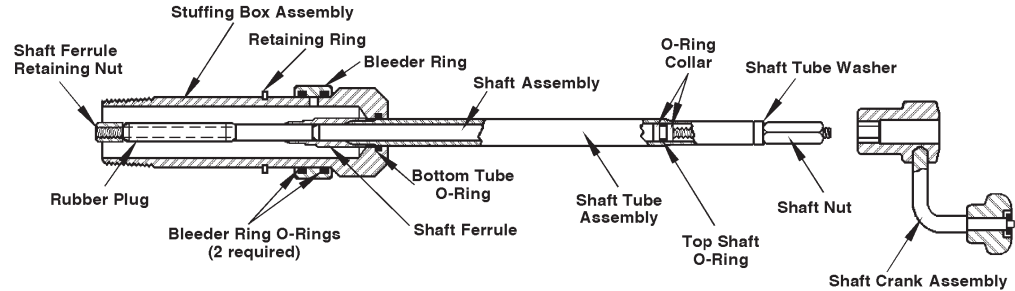

Part Name	Plugging Unit Size*	
	1/2" x 3/4"***	1/2" x 1"***
Plugging Unit Complete	H-17016 - 163	H-17016 - 164
Stuffing Box Assembly (includes 4 items below)	681219	681299
Bottom Tube O-ring	79514	79514
Retaining Ring	53777	50990
Bleeder Ring	50936	50947
Bleeder O-ring (2)	40709	79351
Shaft Crank Assembly	83276	83276
Shaft Nut	509757	509757
Shaft Tube Washer	51159	51159
Top Shaft O-ring	53856	53856
Shaft Tube Assembly	681301	681301
Shaft Assembly	681300	681300
Rubber Plug	509786	509786
Shaft Ferrule Retaining Nut	509665	509665

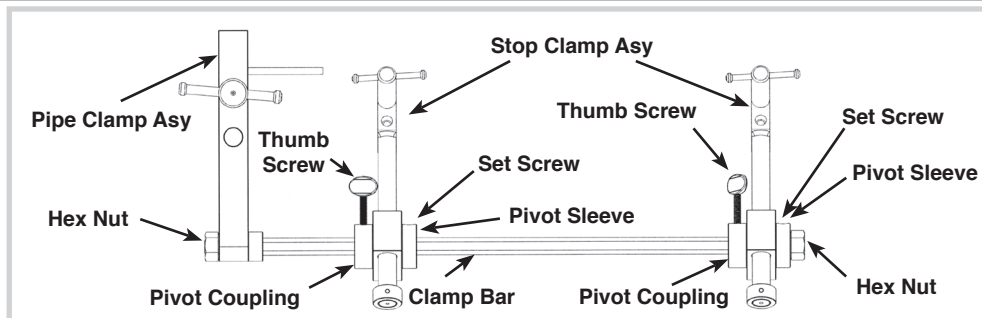

Part Name	Qty Req'd	Part Number
Safety Clamp Complete		682597
Pivot Sleeve	2	537866
Set Screw	2	97763
Pivot Coupling	2	537865 (Pivot Coupling)
Shaft Tube Clamp Arm Assembly (2)	2	682854
Clamp Bar	1	682598
Pipe Clamp Assembly	1	83977
Thumb Screw	2	95297
Hex Nut	2	94825

*Nominal

**Second dimension number refers to meter size.

Rev 12-12 Shaded area indicates a change

- ❑ Catalog number – **H-17017**
- ❑ For changing out 3/4" meter valves installed on 1/2" schedule 40 steel pipe
- ❑ Includes one plugging unit, safety clamp (682597), wooden storage chest (680350) and operating instructions (Form 8540)
- ❑ Fits most roundway and straightway valves
- ❑ O-ring sealed body and stem
- ❑ Maximum working pressure 60 psig** (414 kPa)

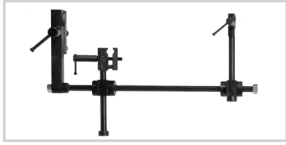

H-17017

Dimensions

The H-17017 plugging units can be used on valves (roundway or straightway) that have minimum port dimensions charted to the right, and if the outlet of the valve has F.I.P. threads.

Valve Size*	Minimum Port Width	Minimum Port Height
3/4"	13/32"	23/32"

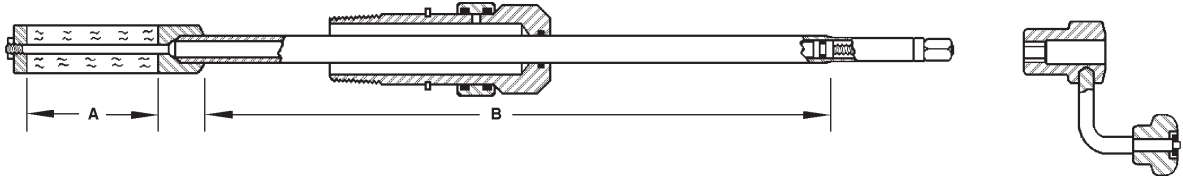

Size* of Plugging Unit	1/2" x 3/4"
Plugging unit part number	01701010 – 250
A length of rubber plug	2"
B length from ferrule shoulder to taper	12-9/16"

Safety Clamp

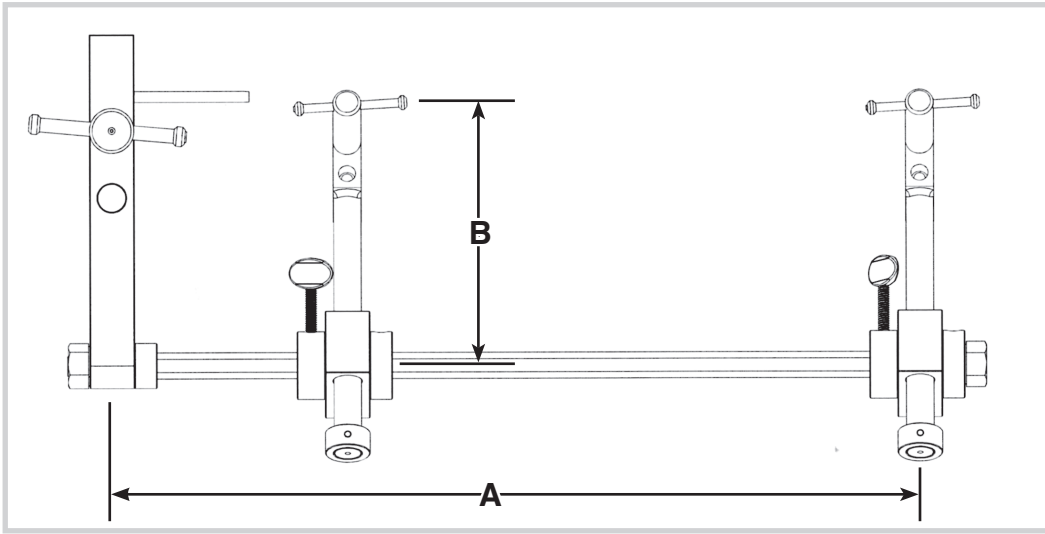

Safety Clamp Part Number	A	B
682597	20"	6-1/2"

*Nominal
 ** This is the maximum working pressure of this equipment. During the use of this equipment, the line pressure must not exceed the amount indicated.

H-17017 VALVE CHANGER REPLACEMENT PARTS

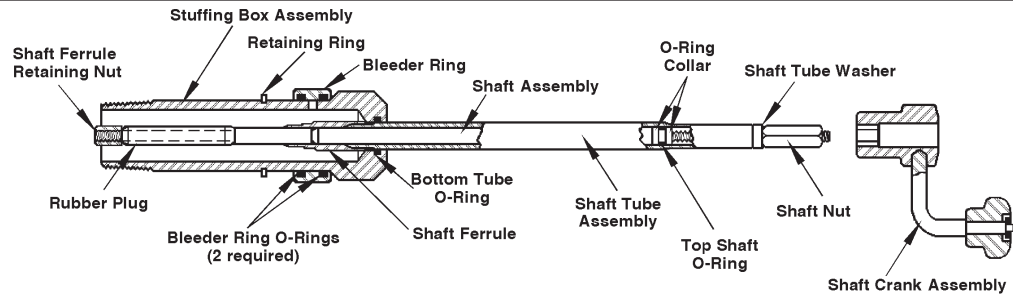

Part Name	Plugging Unit Size*	
	1/2" x 3/4"	
Plugging Unit Complete	01701010 – 250	
Stuffing Box Assembly	681582	
Bottom Tube O-ring		79514
Retaining Ring		53777
Bleeder Ring		50936
Bleeder O-ring (2)		40709
Shaft Crank Assembly	83276	
Shaft Nut	51134	
Shaft Tube Washer	51159	
Top Shaft O-ring	53856	
Shaft Tube Assembly	89259	
Shaft Assembly	83815	
Rubber Plug	503466	
Shaft Ferrule	503465	
Shaft Ferrule Retaining Nut	52969	

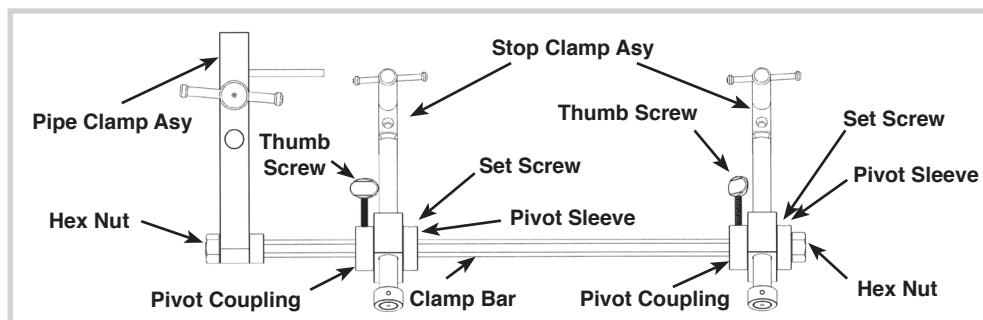

Part Name	Qty Req'd	Part Number
Safety Clamp Complete		682597
Pivot Sleeve	2	537866
Set Screw	2	97763
Pivot Coupling	2	537865 (Pivot Coupling)
Shaft Tube Clamp Arm Assembly (2)	2	682854
Clamp Bar	1	682598
Pipe Clamp Assembly	1	83977
Thumb Screw	2	95297
Hex Nut	2	94825

*Nominal



GAS PRODUCTS DIVISION

www.muellergas.com • moreinfo@muellercompany.com
